



**Warewashing
Undercounter, single skin, pressure
boiler, drain pump, detergent and
rinse aid dispensers, 540d/h**

ITEM # _____

MODEL # _____

NAME # _____

SIS # _____

AIA # _____

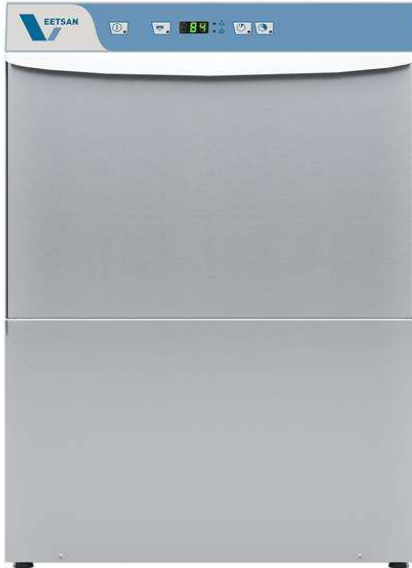

400249 (VL3G)

Undercounter dishwasher with single skin, pressure boiler, built-in drain pump, detergent and rinse aid dispensers, 3 phase, 540d/h

Short Form Specification

Item No. _____

Unit shall be Undercounter dishwasher type hot water rinsing using rack dimension of 500*500mm. Electrical characteristics to be 400 volts three phase 50Hz operation, convertible to single phase on-site. Washing performance is ensure by a powerful wash pump, large capacity wash tank, upper and lower revolving spray arms. Soft start wash pump to avoid accidental breakage of crystal wares. Rinse temperature and pressure guaranteed by built in pressure boiler. Uses 3 liters of clean water per final rinse. Two automatic cycles for different types of wares. Double skin insulated door. 304 AISI stainless steel construction to include door, external panels, frame and wash tank. Electronic control with temperature display. Automatic self-cleaning cycle. The unit shall include drain pump, detergent and rinse aid dispenser pumps and is equipped with electric cable.

Main Features

- Fully automatic self-cleaning cycle avoids the risk of bacteria proliferation.
- State-of-the-art electronic controls with built-in programming, self-diagnostics for serviceability and automatic interior self-cleaning cycle.
- 4 second (variable) pause after washing and before rinsing ensures that no drops of unclean water will fall on the clean items at the end of the rinsing cycle.
- An effective rinse system uses only 3 liters of clean hot water per basket for lower running costs.
- Incorporated Soft Start feature to offer additional protection to more delicate items.
- Built-in pressure boiler sized to raise incoming 50 °C water to guarantee a minimum rinsing temperature of 82 °C for sanitizing rinse. No external booster is required.
- Built-in rinse aid and detergent dispenser with automatic initial and continuous cycle loading for perfect result while minimizing service and maintenance needs.
- Digital read-out keeps operator informed as to temperatures.
- IPx4 water protection.
- Three phase or single phase electrical connection, convertible on-site.
- Unique temperature interlock guarantees required temperatures in both the wash and final rinse.
- Washing system endowed with rotating washing arms, high powered wash pump and large capacity boiler for professional washing.
- Simple control panel with digital display allows on-site personalization of washing and rinsing cycle times and temperatures as well as precise rinse aid and detergent quantities to suit customer's needs.
- Simple service from the front.
- Pre-arrangement for HACCP system implementation and Energy Management device.
- Washing capacity of 30 baskets or 540 dishes per hour.

Construction

- Unit to feature smooth surfaces to facilitate cleaning.
- Incorporated drain pump to control water level in wash tank draining.
- Element protection from dry fire and low water.
- Interchangeable wash/rinse arms screw out for simple clean up.
- The boiler drain facilitates the evacuation of stagnant water after long periods of inactivity to ensure a higher level of hygiene.
- Double skin insulated door to reduce heat dispersion.
- Front and side panels, door and wash tank made in heavy duty anti-corrosive AISI 304 stainless steel.
- 304 stainless steel boiler with higher welding protection to increase resistance to corrosion.
- PVC water supply hose with metal connections resistant to high water pressure.
- Completely closed on the back by a cover plate.
- Large wash tank with round corners and no pipes to avoid dirt built-up.
- Unit to feature drain pump, rinse aid and detergent dispenser pumps.

APPROVAL: _____

**Warewashing
Undercounter, single skin, pressure boiler, drain pump,
detergent and rinse aid dispensers, 540d/h**

Included Accessories

- 1 of Yellow cutlery container PNC 864242
- 1 of Basket for 18 dinner plates - yellow PNC 867002

Optional Accessories

- External manual water softener - 12 lt PNC 860412
- External automatic water softener - 8 lt PNC 860413
- Stand for undercounter dishwasher PNC 860418
- External manual water softener - 20 lt PNC 860430
- Integrated HACCP kit for dishwashers PNC 864001
- External detergent level probe kit PNC 864004
- External rinse aid level probe kit PNC 864005
- KIT 4 FLANGED FEET (MARINE FEET) FOR UC DW PNC 864009
- Stainless steel inlet hose kit PNC 864016
- Filter for partial demineralization PNC 864017
- Kit to measure total/partial water hardness PNC 864050
- Rinse booster pump kit for single tank pressure dishwasher PNC 864051
- Stainless steel tank filter for single skin undercounter PNC 864222
- Yellow cutlery container PNC 864242
- Filter for total demineralization PNC 864367
- Pressure reducer for single tank dishwasher PNC 864461
- Half size basket universal PNC 864527
- Half size basket for plates PNC 864528
- Half size basket for glasses PNC 864529
- Kit 4 plastic boxes for cutlery - yellow PNC 865574
- Basket for 18 dinner plates - yellow PNC 867002
- Basket for cups and coffee cups (24-48 pcs) - blue PNC 867007
- Cover rack for small and light items (500x500 baskets) PNC 867016
- Basket for 16 glasses max. height: 70 mm - blue PNC 867023
- KIT HACCP EKIS PNC 922166

Front

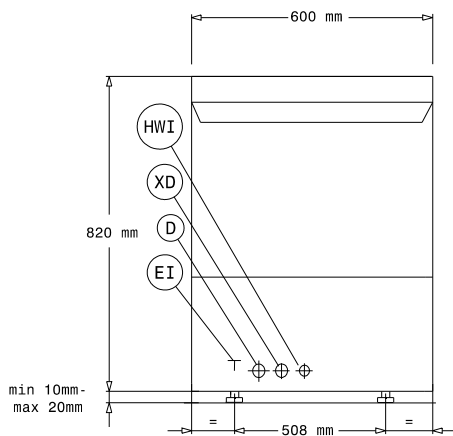

Side

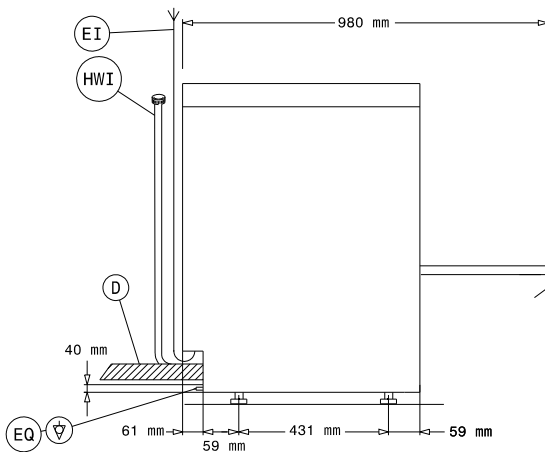

- D** = Drain
- EI** = Electrical inlet (power)
- EO** = Electrical Outlet
- HWI** = Hot water inlet
- XD** = Detergent connection
- XR** = Rinse aid connection

Top

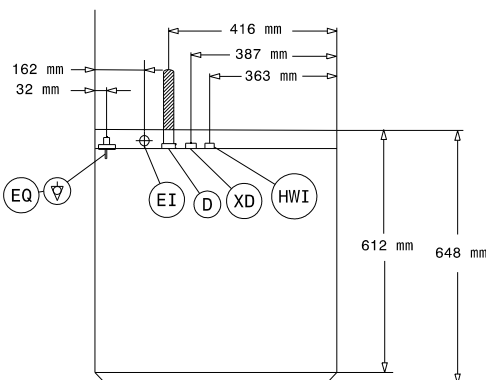

Electric

Supply voltage:	
400249 (VL3G)	400 V/3N ph/50 Hz
Default Installed Power:	5.35 kW
Boiler heating elements:	4,5 kW
Tank heating elements:	2 kW
Wash pump size:	0.736 kW

Water:

Pressure, bar min/max:	2-3 bar
Water supply temperature*:	50 °C
Drain line size:	20.5mm
Inlet Water supply pressure:	29 - 44 psi (2 - 3 bar)
Washing tank capacity (lt):	33
Water consumption per cycle (lt):	3
Boiler Capacity (lt):	5,8

Key Information:

Baskets per hour*:	30
Dishes per hour:	540
Working cycles time (sec.):	120/180
Wash temperature:	55-65°C
Rinse temperature:	80-90 °C
Cell dimensions - width:	500 mm
Cell dimensions - depth:	500 mm
Cell dimensions - height:	330 mm
External dimensions, Width:	600 mm
External dimensions, Height:	820 mm
External dimensions, Depth:	648 mm
Packaging size (WxDxH):	600x610x820 mm
Noise level:	<70 dBA