



**Warewashing
Undercounter Dishwasher, double
skin with atmospheric oiler, drain
pump & detergent dispensers,40r/h**

ITEM # _____

MODEL # _____

NAME # _____

SIS # _____

AIA # _____



502021 (VUCAIG)

Undercounter dishwasher, double skin, insulated with atmospheric boiler, drain pump, detergent and rinse aid dispensers, 40 racks/h or 720 plates/h

Short Form Specification

Item No. _____

Unit shall be undercounter type hot water rinsing dishmachine with atmospheric boiler. Electrical characteristics to be ___400 volts three phase operation with two automatic cycles of 90/180 seconds for normal and heavily soiled items. Rinse temperature and pressure guaranteed by built in atmospheric boiler and built in rinse booster pump. Washing performance is guaranteed by a powerful wash pump, upper and lower stainless steel revolving washing spray arms. Double skin insulated cabinet and door for silent operation. 304 Stainless steel construction to include door, frame, wash tank, wash and rinse arms. The unit shall include drain pump, detergent and rinse aid dispenser pumps.

Main Features

- Built-in atmospheric boiler sized to raise incoming 50 °C water to 84 °C minimum for sanitizing rinse. No external booster is required.
- Constant temperature of 84 °C throughout the rinsing cycle regardless of the network's water pressure and temperature.
- Unique temperature interlock guarantees required temperatures in both the wash and final rinse.
- Washing capacity of 40 baskets or 720 dishes per hour.
- Incorporated Soft Start feature to offer additional protection to more delicate items.
- High efficiency air gap (class A) in water inlet circuit to avoid water being siphoned back into the network as a result of a sudden drop in main pressures.
- 4 second (variable) pause after washing and before rinsing ensures that no drops of unclean water will fall on the clean items at the end of the rinsing cycle.
- Fault auto-diagnosis system.
- An effective rinse system uses only 3 litres of clean hot water per basket for lower running costs.
- Double skinned insulated wall ensures a low noise level and a reduction in heat loss from the machine.
- Utilizes fresh hot rinse water.
- Unique strainer to enhance soil filtering.
- Three phase or single phase electrical connection, convertible on-site.
- Built-in rinse aid and detergent dispenser with automatic initial and continuous cycle loading for perfect result while minimizing service and maintenance needs.
- Low noise level.
- IPX 4 water protection.
- Digital read-out keeps operator informed as to temperatures.
- Simple control panel with digital display allows on-site personalization of washing and rinsing cycle times and temperatures as well as precise rinse aid and detergent quantities to suit customer's needs.
- Equipped with drain pump for easy and quick installation without opening the machine.
- 90/180 seconds cycle.

Construction

- Heavy duty Stainless steel construction.
- Internal cavity as well as exterior panels are all 304 series Stainless steel.
- Special designed Stainless steel nozzles provide superior cleaning action.
- Revolving Stainless steel wash/rinse arms above and below the basket.
- Interchangeable wash/rinse arms screw out for simple clean up.
- Large deep drawn wash tank and internal wash area with round corners and no pipes to avoid dirt built-up.
- Element protection from dry fire and low water.
- The boiler drain facilitates the evacuation of stagnant water after long periods of inactivity to ensure a higher level of hygiene.

APPROVAL: _____

**Warewashing
Undercounter Dishwasher, double skin with atmospheric oiler,
drain pump & detergent dispensers,40r/h**

Included Accessories

- 2 of Cutlery container - yellow PNC 864242
- 1 of Basket for 18 dinner plates 240mm - yellow PNC 867002
- 1 of Basket for 48 small cups/24 cups - blue PNC 867007

Optional Accessories

- 12lt external manual water softener PNC 860412
- 8lt external automatic water softener PNC 860413
- Stand for undercounter dishwasher PNC 860418
- 20lt external manual water softener PNC 860430
- BRASS INLET VALVE KIT FOR UC AND HT PNC 864000
- Integrated HACCP kit PNC 864001
- HACCP printer kit PNC 864002
- External detergent level probe kit PNC 864004
- External rinse aid level probe kit PNC 864005
- Kit 4 castors for double skinned undercounter dw PNC 864008
- Filter for partial demineralization PNC 864017
- Kit to measure total and partial water hardness PNC 864050
- Cutlery container - yellow PNC 864242
- AISI 304 stainless steel back panel for undercounters EUCAI, with a window for air gap - UK PNC 864269
- Filter for total demineralization PNC 864367
- Reverse osmosis filter for single tank dishwasher with atmosphere boiler PNC 864388
- Pressure reducer for single tank dishwasher PNC 864461
- Half size basket universal PNC 864527
- Half size basket for plates PNC 864528
- Half size basket for glasses PNC 864529
- Kit 4 plastic boxes for cutlery - yellow PNC 865574
- Basket for 18 dinner plates 240mm - yellow PNC 867002
- Basket for 5 trays 530x325 mm - red, for undercounter (top level), utensil dishwashers, hood type, rack type PNC 867006
- Basket for 48 small cups/24 cups - blue PNC 867007
- Wire basket for 12 plates up to 320 mm PNC 867014
- Cover rack for small and light items (500x500 baskets) PNC 867016
- Basket for long stem wine glasses PNC 867019
- Basket for 16 vertical glasses (h 70 mm - diam 100 mm) - blue PNC 867023
- Basket semi-professional 500x500x190mm PNC 867024

Front

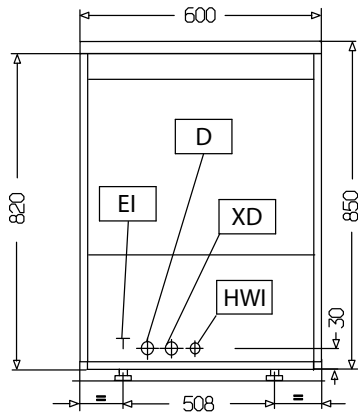

Top

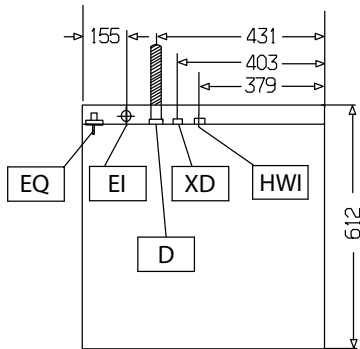

Side

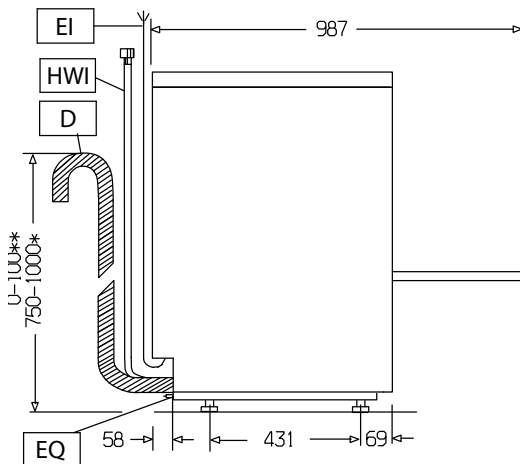

- D** = Drain
- EI** = Electrical inlet (power)
- EO** = Electrical Outlet
- HWI** = Hot water inlet
- V** = Air vents
- XD** = Detergent connection
- XR** = Rinse aid connection

Electric

Supply voltage:	
502021 (VUCAIG)	400 V/3N ph/50 Hz
	230V 1N~;
Convertible to:	230V 3~
Total Watts:	5.35 kW
Tank heating elements:	2 kW

Water:

Water supply temperature*:	50 °C
Drain line size:	20.5mm
Inlet Water supply pressure:	7 - 102 psi (0.5 - 7 bar)
Water consumption per cycle (lt):	3
Boiler Capacity (lt):	12
Tank Capacity (lt):	23
Washing cycle temperature:	55-65 °C
Hot rinse cycle temperature:	84 °C
Hot rinse cycle water consumption (lt):	3

Key Information:

Baskets per hour*:	40
N° of working cycles - sec.:	2 (90/180)
Cell dimensions - width:	500 mm
Cell dimensions - depth:	500 mm
Cell dimensions - height:	335 mm
Dishes per hour:	720
Wash temperature:	55-65°C
Rinse temperature:	84 °C
External dimensions, Height:	850 mm
External dimensions, Width:	600 mm
External dimensions, Depth:	612 mm
Net weight:	68 kg
Shipping weight:	75 kg
Shipping height:	1020 mm
Shipping width:	670 mm
Shipping depth:	740 mm
Shipping volume:	0.51 m³
Noise level:	<65 dBA