



## Dishwashing Single rinse Rack type with Energy Saving Device and Medium Dryer, 100R/H, Electric, 50Hz

ITEM # \_\_\_\_\_

MODEL # \_\_\_\_\_

NAME # \_\_\_\_\_

SIS # \_\_\_\_\_

AIA # \_\_\_\_\_



CC0ECH (VSR10E5ED)

Single rinse rack type dishwasher with Energy Saving Device, 100 racks/hour, electric, touch screen, insulated doors, customized direction on-site

### Short Form Specification

Item No. \_\_\_\_\_

Unit to be Veetsan single rinse rack type dishwasher. Equipped Energy Saving Device (ESD) recovers the heat inside the machine to heat up incoming cold water to the boiler. Single rinse with built-in stabilized pressure valve ensures the right rinsing pressure for optimum hygiene results. Maximum Water Contact (MWS) wash arms are positioned along the full length of the wash tank. Powerful wash pump and specially designed wash spray arms guarantee cleaning. Washing is done with water circulating at 55-65°C. Final rinsing is done with clean water heated up to 85°C. Low rinse water consumption of 1.5 liters per rack at maximum speed of 100racks/hour. Equipped medium dryer provides dry dishes using both internal and external air. One conveyor speed of 100racks per hour. Intuitive touch screen control panel provides easy communication on different levels. Large counter-balance door has heat and noise insulation with easy internal access. Easy drain of water done through control panel. Standard end of the day self cleaning cycle and sanitation cycle. Operating direction of the machine (right to left or left to right) is decided by customer on-site depending on the layout flow.

### Main Features

- Adjustable feet for full access underneath the machine for cleaning.
- Electronically controlled to optimize drying results.
- Drying zone removes most of water from the crockery through a high powered fan that extracts dry air from outside mixing it with the internal air, thus providing dry plates at a temperature cool enough to handle safely.
- IP25 protection against water jets, solid objects and small animals (larger than 6 mm).
- Auto-start/stop equipped in different zones ensures that the zone runs only when a rack is passing through it. This reduces water, energy, chemical consumption and noise.
- Intuitive touch screen control panel features user-friendly display to easily operate the machine and to monitor machine status. Three different levels of interaction are available each show relevant messages and information to the operator, the general maintenance staff and the authorized service partners.
- All internal components: wash and rinse arms, tank filters, curtains can be easily removed for cleaning.
- Unit equipped with USB port making it simple to read data such as machine identification, counters and consumption, components, devices and alarm logs. Machine parameters can be uploaded and downloaded and firmware updated.
- Maximum capacity per hour of 100 racks.
- Large counter balanced inspection door allow unrestricted all-round access to the wash and rinse area. Door is insulated with injected foam. This adds strength as well as reduces noise and heat loss.
- Single rinse with stabilized pressure valve guarantees rinse water consumption of 1.5 liters/ rack regardless of inlet water pressure to ensure low energy, water, detergent and rinse aid consumption.
- Built-in stabilized pressure valve ensures constant pressure throughout the rinsing cycle regardless of inlet water pressure.
- One conveyor speed can be selected through the control panel by the operator.
- Self-draining vertical wash pumps provide maximum hygiene.
- Automatic back-up mode is activated when a failure occurs. Guided troubleshooting for fast fixes including 150 precises notifications and 23 easy-to-follow processes.
- Built-in Energy Saving Device (ESD) utilizes the hot steam generated by the machine in the rinse and wash tank to heat up incoming cold water to up 50°C before entering the boiler, thus saving energy.

### Construction

- Deep drawn pressed wash tank with fully rounded corners, sloped towards the drain to prevent dirt

APPROVAL: \_\_\_\_\_

Dishwashing  
Single rinse Rack type with Energy Saving Device and Medium  
Dryer, 100R/H, Electric, 50Hz

buildup, provides fast drainage in just a few minutes. With no welding points the pressed tank offers a guaranteed water tight solution.

- Dishwasher structure is held together with a solid 50 x 50 mm stainless steel frame to provide long-term sturdiness.
- All electric components are put in one IP65 central box isolated from water and steam to ensure high reliability.
- External pre-arrangement for inlet water, drain water, detergent & rinse aid connections for fast and easy installation on both sides of the unit.
- The chamber is pressed with fully rounded corners without internal pipes and therefore no hidden dirt traps.
- All main components made in heavy duty anti-corrosive 304 type stainless steel: internal chamber, external, front and side panels and rack transportation system.
- The feeding direction is right to left as pre-arrangement from the factory, but it can be simply reversed on-site to left to right.
- The unit is built on modularity concept for easy to install on-site.

### Optional Accessories

- Kit end limit switch for Rack Type dishwasher PNC 864138
- Connection bracket for plain undershelf and grid undershelf (to be used if roller conveyor is connected directly to Rack Type Dishwasher with splash hood) PNC 865235
- Kit water softener for Rack Type dishwasher PNC 865284
- Pair of legs for long conveyors connected directly to the Rack Type Dishwasher with hot air blower PNC 865477
- HACCP cable connection for Rack Type dishwasher PNC 865490
- Splash hood kit for single-rinse Rack Type Dishwasher, 200 mm PNC 865498
- Silicon courtains for single rinse Rack Type dishwasher PNC 865503
- Set of 6 baskets: 2 for trays, 2 for plates, 1 for cutlery and 1 for cups PNC 867050
- Set of 9 baskets: 2 for trays, 3 for plates, 2 for cutlery and 2 for cups PNC 867051
- Connectivity hub (router) PNC 922697
- Connectivity hub (router and sim card) PNC 922705

### Components

- 1 of **534409** (VSR10E5) Single rinse rack type dishwasher, 100 racks/hour, electric, touch screen, insulated doors, customized direction on-site, 50Hz
- 1 of **534059** (NMHSDRE56) Medium hot air blower zone without door for single rinse Rack Type Dishwasher, 50Hz & 60Hz
- 1 of **864478** (NESDSRE) ESD for single-rinse Rack Type dishwasher, electric

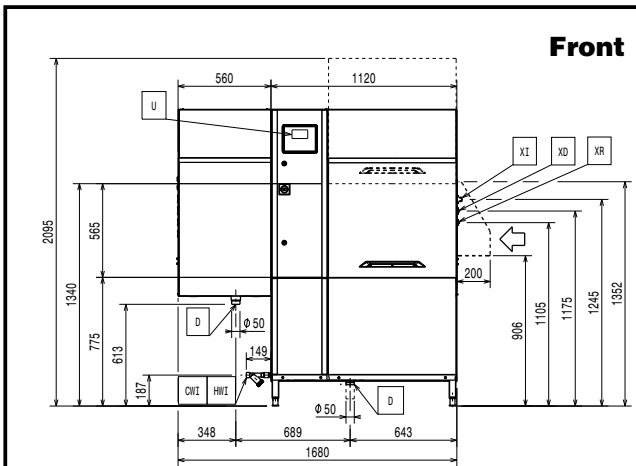

**Front**

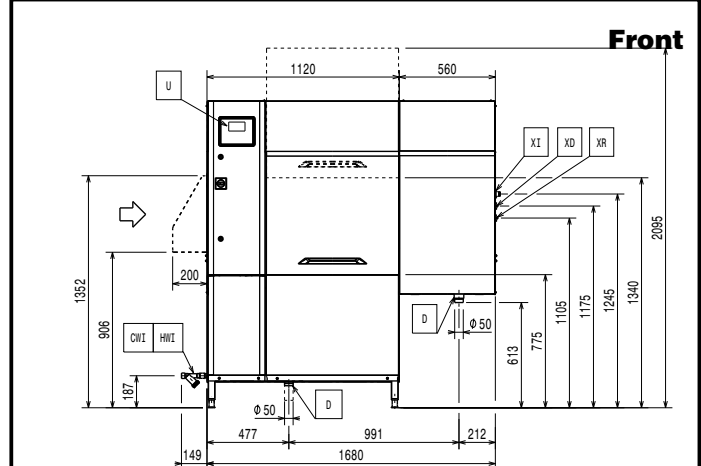

**Front**

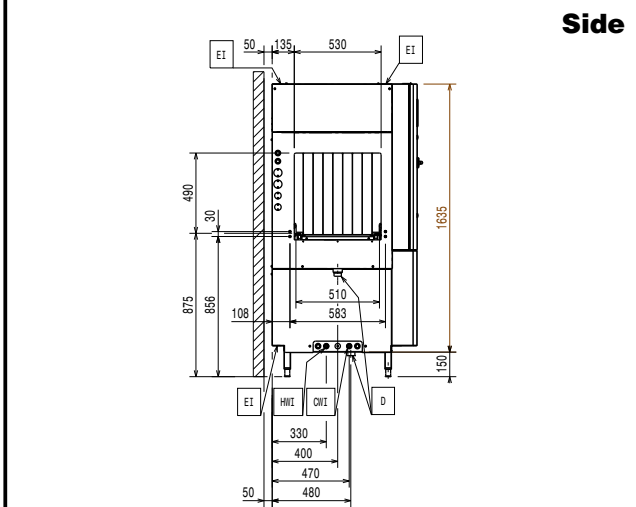

**Side**

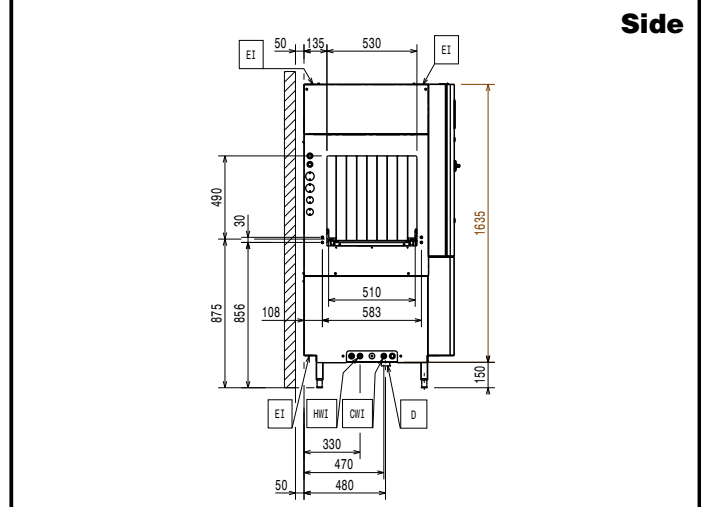

**Side**

**CWI** = Cold Water Inlet      **XP** = Chemical probe/sensor

**CWI** = Cold Water Inlet      **XP** = Chemical probe/sensor

- D** = Drain
- EI** = Electrical inlet (power)
- EO** = Electrical Outlet
- EQ** = Equipotential screw
- ES** = Electrical signal IN/OUT
- U** = USB port
- WI** = Water inlet

- D** = Drain
- EI** = Electrical inlet (power)
- EO** = Electrical Outlet
- EQ** = Equipotential screw
- ES** = Electrical signal IN/OUT
- U** = USB port
- WI** = Water inlet

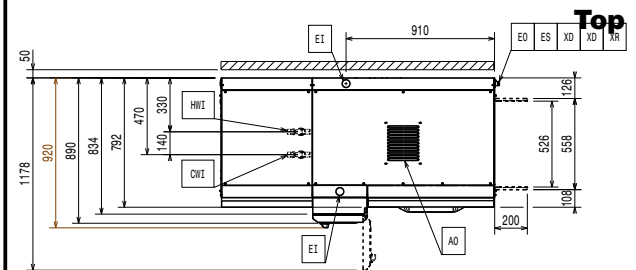

**Top**

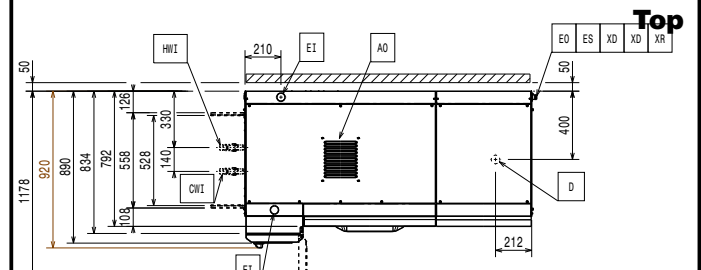

**Top**

### Electric

|                                    |                       |
|------------------------------------|-----------------------|
| <b>Supply voltage:</b>             |                       |
| <b>CC0ECH (VSR10E5ED)</b>          | 380-415 V/3N ph/50 Hz |
| <b>Default Installed Power:</b>    | 30 kW                 |
| <b>Boiler heating elements:</b>    | 12 kW                 |
| <b>Wash pump size:</b>             | 1.18 kW               |
| <b>Wash tank heating elements:</b> | 12 kW                 |

### Water:

|   |           |
|---|-----------|
| <b>Flow rate of wash pump:</b>                          | 400 l/min |
| <b>Inlet water line size:</b>                           | G 3/4"    |
| <b>Inlet cold water line size:</b>                      | G 3/4"    |
| <b>Drain line size:</b>                                 | 50mm      |
| <b>Inlet water supply pressure:</b>                     | 1.5-7 bar |
| <b>Inlet water supply temperature (wash&amp;rinse):</b> | 10 - 65°C |

The higher the temperature, the faster the warm up.

|                                     |                   |
|-------------------------------------|-------------------|
| <b>Inlet water supply hardness:</b> | 0-14 °fH / 0-8°dH |
|-------------------------------------|-------------------|

When below 7°fH/4°dH special detergent and rinse aid are needed.

|                                 |         |
|---------------------------------|---------|
| <b>Flow rate of wash pump:</b>  | 400 l/h |
| <b>Peak rate of drain flow:</b> | 2.5 l/s |
| <b>Wash tank size:</b>          | 70 l    |

### Key Information:

|   |                     |
|---|---------------------|
| <b>Final rinse temperature:</b>                         | 85 °C               |
| <b>Wash Temperature:</b>                                | 55 - 65 °C          |
| <b>Rinse water consumption at max. speed (l/rack)*:</b> | 1.5                 |
| <b>Rinse water consumption at max. speed (l/h)**:</b>   | 150                 |
| <b>Productivity per hour (max speed):</b>               | 100racks/1800dishes |
| <b>Dryer air flow:</b>                                  | 540 m³/h            |
| <b>Dryer air temperature:</b>                           | 50-70 °C            |
| <b>Drying fan capacity:</b>                             | 540 m³/h            |
| <b>External dimensions, Width:</b>                      | 1680 mm             |
| <b>External dimensions, Depth:</b>                      | 920 mm              |

For transportation purpose only, the depth can be reduced to either 890mm by removing the main switch button or 792mm by removing the control box and the door handle.

|                                     |         |
|-------------------------------------|---------|
| <b>Height with door open:</b>       | 2095 mm |
| <b>Charging hole size (width):</b>  | 530 mm  |
| <b>Charging hole size (height):</b> | 490 mm  |
| <b>Shipping height:</b>             |         |
| <b>Shipping width:</b>              |         |
| <b>Shipping depth:</b>              |         |
| <b>Shipping volume:</b>             |         |
| <b>Table to table distance:</b>     | 1680 mm |

### Air Emission:

|  |                |
|--|----------------|
| <b>Air flow (entrance, exit):</b>        | 243 / 160 m³/h |
| <b>Air temperature (entrance, exit):</b> | 45 / 55 °C     |

**Air humidity (entrance, exit):** 100 / 60 % r.h.

The data is measured at exhaust points at 25°C and 60% r.h. ambient conditions, 18°C inlet water temperature and refer only to the machine.

**Latent heat:** 13500 W

**Sensible heat:** 8300 W

This model requires a ventilation hood. Please refer to the attached "Recommended Exhaust Hood Design".

## RECOMMENDED TABLE CONNECTION

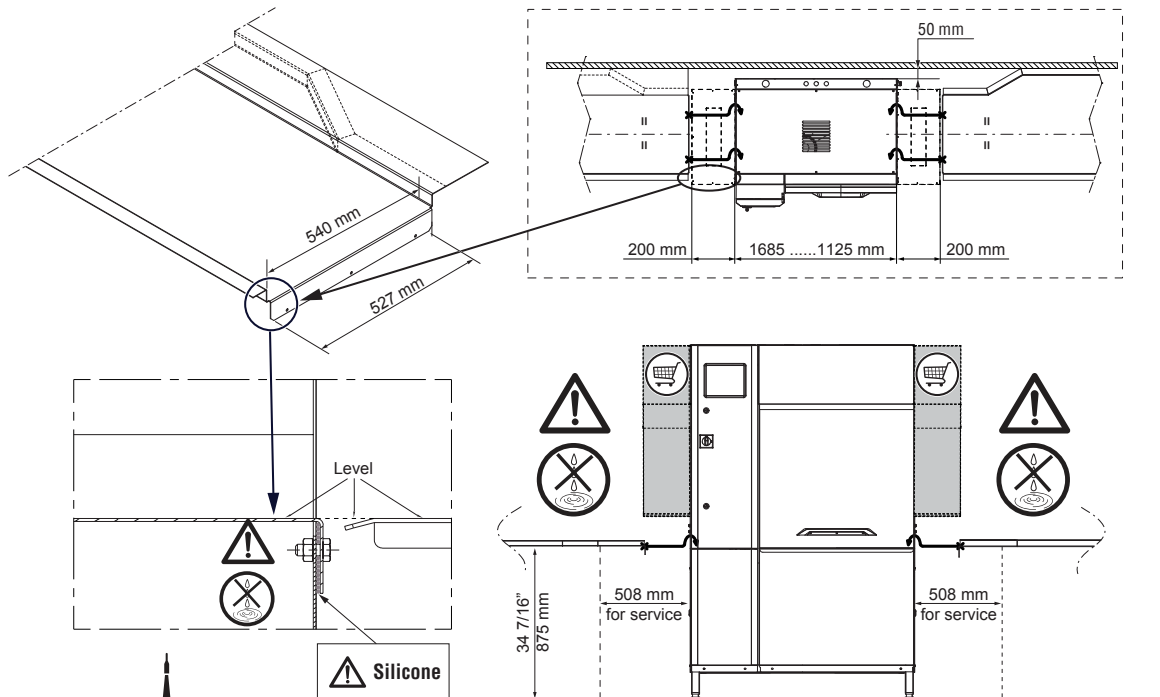

**!** Apply silicone between the machine and the table and make sure that there are not any water leakages. Reference code 059611 for recommended silicone by Electrolux.

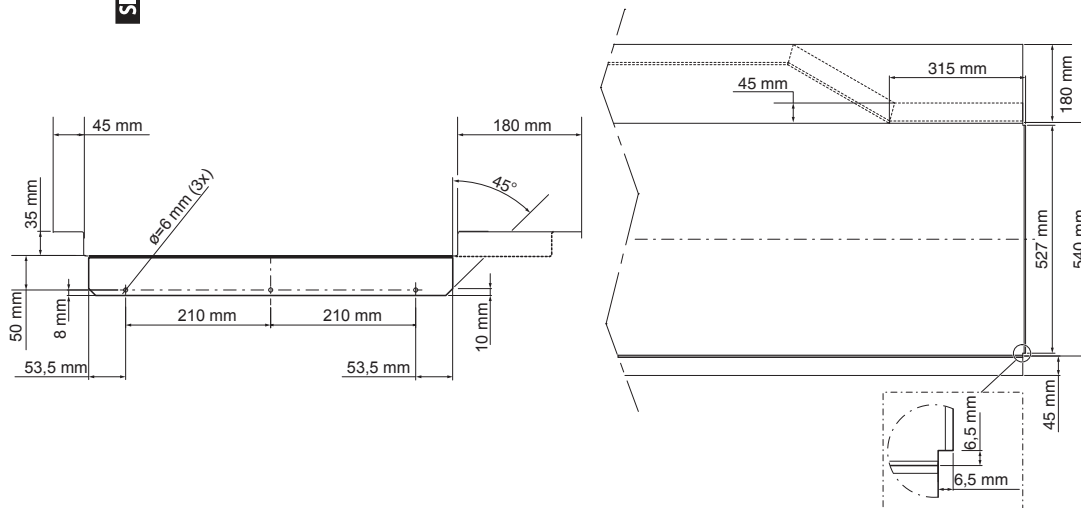

All tables must be connected to the dishwashing units according to local regulations and industry standards which may differ from the recommendations herein suggested. Electrolux Professional is not liable for any failure in complying with local design standards.

DOC. NO. 59566QD00  
EDITION 01.2018

### RECOMMENDED HOOD DESIGN OPTIONS

**NO ESD = ✓  
ESD = ✓**

| Qtot (VDI 2052)       |           |
|-----------------------|-----------|
| 150 r/h ESD no Dryer  | 1500 m³/h |
| 200 r/h ESD no Dryer  | 1700 m³/h |
| 250 r/h ESD no Dryer  | 1900 m³/h |
| 150 r/h ESD + 1 Dryer | 1500 m³/h |
| 200 r/h ESD + 1 Dryer | 1700 m³/h |
| 250 r/h ESD + 1 Dryer | 1900 m³/h |

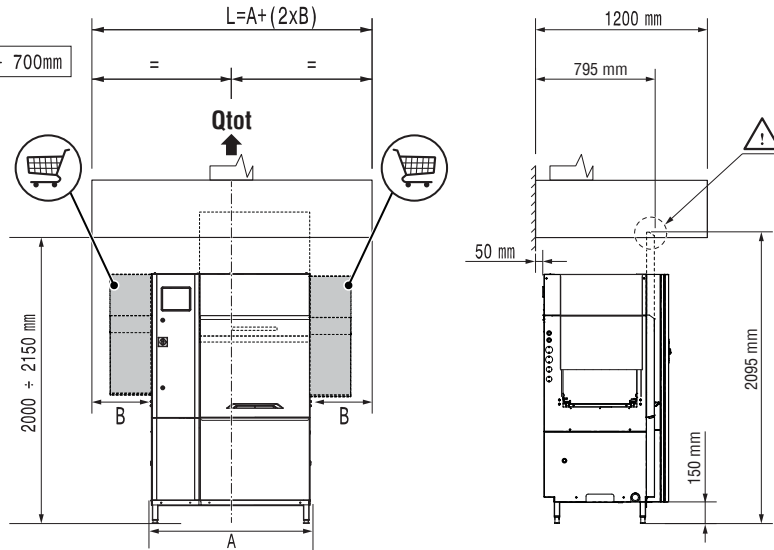

**NO ESD = ✓  
ESD = ✗**

| Qtot (VDI 2052)       |           |
|-----------------------|-----------|
| 150 r/h ESD no Dryer  | 1500 m³/h |
| 200 r/h ESD no Dryer  | 1700 m³/h |
| 250 r/h ESD no Dryer  | 1900 m³/h |
| 150 r/h ESD + 1 Dryer | 1500 m³/h |
| 200 r/h ESD + 1 Dryer | 1700 m³/h |
| 250 r/h ESD + 1 Dryer | 1900 m³/h |

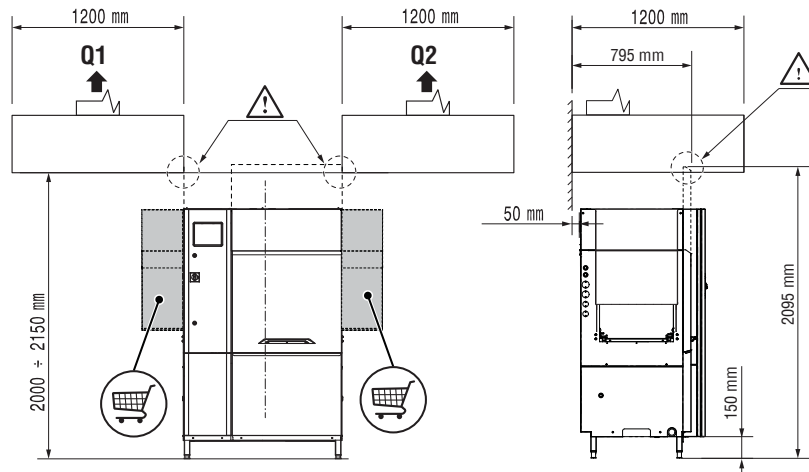

**NO ESD = ✓  
ESD = ✗**

| Qtot (VDI 2052)       |           |
|-----------------------|-----------|
| 150 r/h ESD no Dryer  | 1500 m³/h |
| 200 r/h ESD no Dryer  | 1700 m³/h |
| 250 r/h ESD no Dryer  | 1900 m³/h |
| 150 r/h ESD + 1 Dryer | 1500 m³/h |
| 200 r/h ESD + 1 Dryer | 1700 m³/h |
| 250 r/h ESD + 1 Dryer | 1900 m³/h |

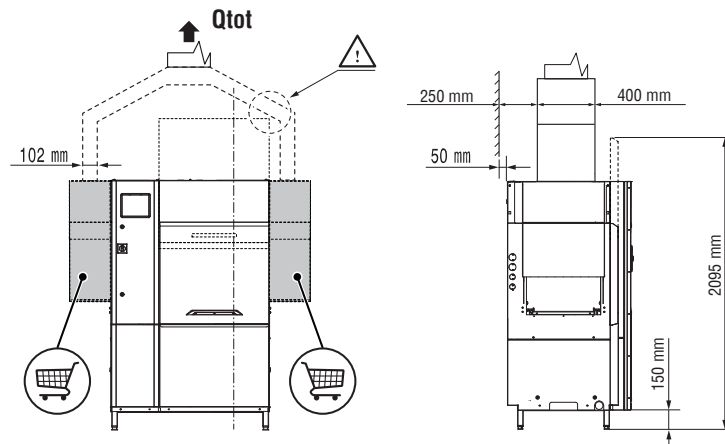

All exhaust hoods must be dimensioned and installed according to local regulations and industry standards which may differ from the recommendations herein suggested. Electrolux Professional is not liable for any failure in complying with local design standards.

DOC. NO. 59566QF00  
EDITION 01.2018